



Sensor TADi with integrated transducer U10b

Functional principle

Measurement of flow according to the heat transfer method

Measured variables

- standard velocity, standard flow rate, mass flow and temperature
- standard conditions adjustable; default:
temperature $t_n = +21\text{ °C}$
pressure $p_n = 1014\text{ hPa}$

Gases

- puren gases, gas mixtures: air, nitrogen, methane, natural gas, propane, butane, argon, carbon dioxide, sulphur hexafluoride, helium, hydrogen, landfill gas, ...
- switching between the calibration characteristics of various measurement gases is possible in running operation

Output variables

- 2 analog outputs 4 ... 20 mA (flow and temperature)
- quantity pulse / limit value
- performance data via WiFi

Design

Measuring tube with transducer integrated in the connection housing

Advantages

- high turndown ratio (up to 1 : 1000)
- measuring range from 0.04 Sm³/h (0.6 Sl/min)
- low measuring uncertainty, even at lowest flow velocities
- direct mass flow measurement; additional pressure and temperature measuring is not necessary
- sensor has no moving parts
- stainless steel sensor housing
- higher working temperature and pressure ranges
- low installation costs
- negligible pressure drop thanks to virtually unrestricted passageway
- high durability and long-term stability
- sterilisable (sensor material resistance allowing)
- optional: LCD with keypad, WiFi
- values can be displayed and parameters set simply via the display and keypad or web interface

Range and examples of application

- measuring
 - compressed air and gas consumption of oxygen, nitrogen, argon e.g. in welding technologies
 - leakage flow
 - outgoing air, burner supply air
 - monitoring inerting of nuclear processes
 - in air in low vacuum range at pressures greater than 200 hPa abs.

Particles, condensation, humidity in the gas

- charges in the gas caused by particles, dust and fibres do not affect the measurement as long as there is no abrasion and no deposit on the sensor
- deviations in values as a result of variable air humidity in normal atmospheric conditions are covered by the measuring uncertainty specifications

Model designation (example)

TA Di	8	G	E	60 m/s	140	p16	ZG3d
(1)	(2)	(3)	(4)	(5)	(6)	(7)	(8)

Basic types

Type	Article no.
TA Di 8 GE 60 m/s / 140 / p16 ZG3d	B016/510
TA Di 8 GE 120 m/s / 140 / p16 ZG3d	B016/510-120M/S
TA Di 8 GE 150 m/s / 140 / p16 ZG3d	B016/510-150M/S
TA Di 16 GE 60 m/s / 140 / p16 ZG1d	B016/511
TA Di 16 GE 120 m/s / 140 / p16 ZG1d	B016/511-120M/S
TA Di 16 GE 150 m/s / 140 / p16 ZG1d	B016/511-150M/S
TA Di 21.6 GE 60 m/s / 140 / p16 ZG1d	B016/512
TA Di 21.6 GE 120 m/s / 140 / p16 ZG1d	B016/512-120M/S
TA Di 21.6 GE 150 m/s / 140 / p16 ZG1d	B016/512-150M/S
TA Di 27.2 GE 60 m/s / 140 / p16 ZG1d	B016/513
TA Di 27.2 GE 120 m/s / 140 / p16 ZG1d	B016/513-120M/S
TA Di 27.2 GE 150 m/s / 140 / p16 ZG1d	B016/513-150M/S
TA Di 35.9 GE 60 m/s / 140 / p16 ZG1d	B016/514
TA Di 35.9 GE 120 m/s / 140 / p16 ZG1d	B016/514-120M/S
TA Di 35.9 GE 150 m/s / 140 / p16 ZG1d	B016/514-150M/S
TA Di 41.8 GE 60 m/s / 140 / p16 ZG1d	B016/515
TA Di 41.8 GE 120 m/s / 140 / p16 ZG1d	B016/515-120M/S
TA Di 41.8 GE 150 m/s / 140 / p16 ZG1d	B016/515-150M/S

(1) Sensor type / design

Thermal flow sensor TA Di designed as measuring tube

(2) Dimensions

measuring tube inside diameter \varnothing Di [mm]	installation length L [mm]	installation height h [mm]	tube connection on both sides
8.0	80 mm + SRV *	95	via onsite tubes 12 x 2 mm
16.0	480	95	Ag R 1/2" ** Gg RP 1/2"
21.6	650	100	Ag R 3/4" ** Gg RP 3/4"
27.2	820	100	Ag R 1" ** Gg RP 1"
35.9	1080	100	Ag R 1 1/4" ** Gg RP 1 1/4"
41.8	1250	105	Ag R 1 1/2" ** Gg RP 1 1/2"

* **SRV** : mechanical joint on both sides

** **Ag** : Whitworth tapered pipe thread according to DIN 2999

Gg : counter thread

Input/output section

to be provided for TA Di 8 on site - tubes 12 x 2 mm, 160 mm (input) / 80 mm (output) laid straight;
no additional input/output section necessary for other measuring tubes; length of
input section 2/3 of installation length L and output section 1/3 of installation length L

(3) Measuring gases

air, clean gases, gas mixtures with constant ratio of mixture

(4) Materials in contact with the medium

stainless steel 1.4571, 1.4305, 1.4404, glass, epoxy resin, silicone (silicone-free on request), Viton®

(5) Measuring ranges* air/nitrogen

basic types / measuring range	in m ³ /h	in kg/h	in l/min	in m/s	1 m ³ /h equates to [m/s]
TA Di 8 ...					
... 60 m/s ...	0.04 ... 11	0.05 ... 13	0.6 ... 181	0.2 ... 60	5.53
... 120 m/s ...	0.04 ... 22	0.05 ... 26	0.6 ... 362	0.2 ... 120	5.53
... 150 m/s ...	0.04 ... 27	0.05 ... 33	0.6 ... 452	0.2 ... 150	5.53
TA Di 16 ...					
... 60 m/s ...	0.15 ... 43	0.18 ... 52	2.4 ... 729	0.2 ... 60	1.38
... 120 m/s ...	0.15 ... 86	0.18 ... 104	2.4 ... 1448	0.2 ... 120	1.38
... 150 m/s ...	0.15 ... 109	0.18 ... 130	2.4 ... 1810	0.2 ... 150	1.38
TA Di 21.6 ...					
... 60 m/s ...	0.27 ... 79	0.32 ... 95	4.4 ... 1319	0.2 ... 60	0.758
... 120 m/s ...	0.27 ... 158	0.32 ... 190	4.4 ... 2638	0.2 ... 120	0.758
... 150 m/s ...	0.27 ... 198	0.32 ... 238	4.4 ... 3298	0.2 ... 150	0.758
TA Di 27.2 ...					
... 60 m/s ...	0.42 ... 125	0.50 ... 151	7.0 ... 2092	0.2 ... 60	0.478
... 120 m/s ...	0.42 ... 250	0.50 ... 300	7.0 ... 4184	0.2 ... 120	0.478
... 150 m/s ...	0.42 ... 314	0.50 ... 377	7.0 ... 5230	0.2 ... 150	0.478
TA Di 35.9 ...					
... 60 m/s ...	0.73 ... 219	0.88 ... 263	12.1 ... 3644	0.2 ... 60	0.274
... 120 m/s ...	0.73 ... 438	0.88 ... 526	12.1 ... 7288	0.2 ... 120	0.274
... 150 m/s ...	0.73 ... 547	0.88 ... 657	12.1 ... 9110	0.2 ... 150	0.274
TA Di 41.8 ...					
... 60 m/s ...	1.0 ... 296	1.2 ... 356	16.5 ... 4949	0.2 ... 60	0.202
... 120 m/s ...	1.0 ... 592	1.2 ... 712	16.5 ... 9880	0.2 ... 120	0.202
... 150 m/s ...	1.0 ... 741	1.2 ... 890	16.5 ... 12350	0.2 ... 150	0.202

* all standard flow rate and standard flow velocity specifications relating to a standard pressure $p_N = 1014 \text{ hPa}$ and a standard temperature $t_p = +21 \text{ °C}$ (294.15 K)

Measurement uncertainty / damping

measurement uncertainty for flow velocities S_v with 1014 hPa and +21 °C in air and gases, as far as calibration performed in real gas

less than / equal to 40 m/s: 2 % v. M. + 0.02 m/s

greater than 40 m/s : 2.5 % v. M.

damping : adjustable to 0.5 s and multiples

Measurable gases

Medium	Calibration	Medium	Calibration
air	calibration in the medium	carbon dioxide (CO ₂)	transformed characteristics
nitrogen (N ₂)	transformed characteristics	landfill gas (40 % CH ₄)	transformed characteristics
argon (Ar)	transformed characteristics	helium (He)	transformed characteristics
methane (CH ₄)	transformed characteristics	hydrogen (H ₂)	transformed characteristics
propane (C ₃ H ₈)	transformed characteristics	custom 1	customised calibration
butane (C ₄ H ₁₀)	transformed characteristics	custom 2	customised calibration

Calibration always performed in air, in addition, characteristics transformation for the described media.

The media stored for the realisation of the smallest measurement uncertainties are generally also calibrated in real gas.

On request, additional calibration data for up to 2 further calibrations can be stored in other media or as special calibrations.

(6) Permissible temperature

medium	-10 ... +140 °C	
ambient	-25 ... +50 °C	
	-20 ... +50 °C	with option 'LCD'

(7) Pressure resistance

max. 16 bar / 1.6 MPa above atmospheric
greater than 16 bar / 1.6 MPa on request

(8) Design

TA Di 8	measuring tube with connection housing and integrated transducer U10b, according to Drawing 3d
TA Di 16 ... 41.8	measuring tube with connection housing and integrated transducer U10b, according to Drawing 1d

Drawing 1d

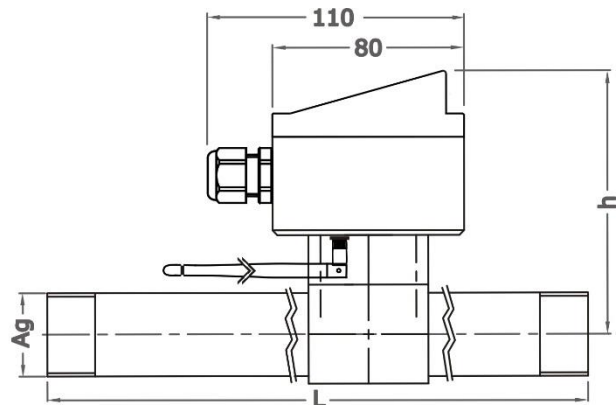
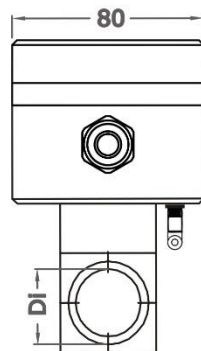

Drawing 3d

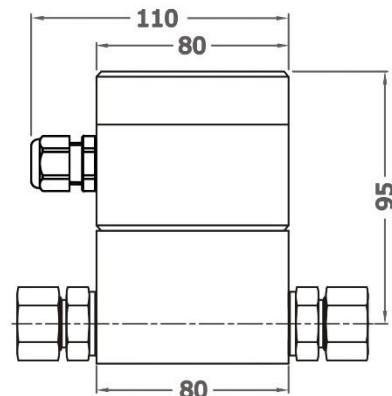
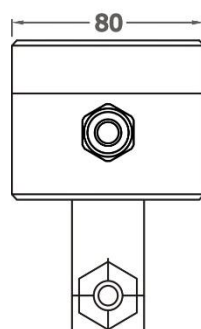

Ingress protection / fitting position

sensor IP68, IEC 529 and EN 60 529
any installation position with atmospheric pressure,
with pressures above atmospheric direction of flow not from above

Connection housing AS80

measurements	80 / 80 / 71 (60) mm (L / W / H)
connection	Cable gland for cables with an outside diameter 5 ... 9 mm, terminal clamps for strands with cross section 0.2 ... 1.5 mm ² . Comply with the standards and regulations applicable to the cable routing.
protection class	IP65, IEC 529 and EN 60 529
Material	powder-coated aluminium

Measuring transducer design U10b, integrated in the sensor connection housing

analog output 1 flow or temperature	4 ... 20 mA (linear), update every 500 ms burden max. 500 Ohm
analog output 2 flow or temperature	4 ... 20 mA (linear), update every 500 ms burden max. 500 Ohm
measured variable flow	Sm/s, Sft/min, Scfm, Sl/s, Sl/min, Sl/h, Sm ³ /s, Sm ³ /min, Sm ³ /h and kg/h counter in Sm ³
measured variable temperature	°C, °F
pulse output	for quantity measurement or as a limit value, open drain, max. 32 V, 20 mA, pulse duration 0.5 s, max. pulse frequency 1 Hz per volume unit SV, internal current limiting, thermal circuit breaker
power supply	24 V DC ± 10 %
power consumption	less than 3 W
housing	AS80
EMC	EN 61 000-6-2 and EN 61 000-6-4
setting parameter	physical variables, initial and final value of the analog outputs, time constants, profile factor, pipe inside diameter, quantity pulse, limit value, working pressure, standard density, WiFi settings and more parameters can be changed via display and keypad or web interface



Display and keypad (optional)



WiFi (optional)

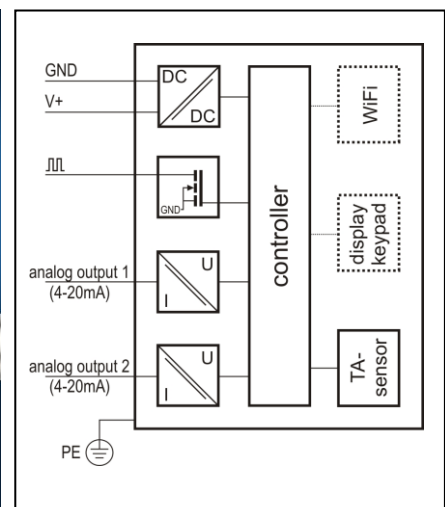

Wiring diagram U10b

Options		
	Description	Article no.
local LCD with keypad and quantity counter	illuminated, in housing cover, multi-row, graphic-capable, temperature range -20 ... +50 °C, display options: - instantaneous value (volume flow and temperature) - volume - graphical overview of the instantaneous values of the last 10 seconds - status information	A010/530
WiFi module	compatible with the WLAN standards IEEE 802.11b/g/n (2.4 GHz), rotatable and pivotable round antenna. Permits parameter setting and display of the measured value course via web interface. Use as local hotspot or integration in the existing WLAN possible.	WIFI
ATEX type of protection category 3G and 3D (zone 2 and 22)	Ex ec IIC T4 Gc X * Ex tc IIIC T135 °C Dc X * * option display and keypad not possible	TAEX2E

Accessories		
	Description	Article no.
calibration certificate Sv	min. 6 standard calibration values	KLB

Höntzsch GmbH

Gottlieb-Daimler-Straße 37
D-71334 Waiblingen (Hegnach)
Telephone +49 7151 / 17 16-0
Fax +49 7151 / 5 84 02
e-mail info@hoentzsch.com
Internet www.hoentzsch.com

® : Registered trademark
from DuPont

Subject to modifications