



# Flow Indicators Flow Monitors DWG

## Operation

The flow monitors operate on the principle of the float type flow indicator.

The float contains permanent magnets.

The reed switch is contained in an adjustable switch housing external to the flow circuit. The flowing medium raises the float in the direction of flow.

As soon as the float with its permanent magnets reaches the contact position, the reeds close together. As the flow increases, the float rises further range i.e. the contact remains closed thus ensuring bistable switching.

The top edge of the float serves to indicate the flowrate on the measuring glass scale.

## Switch range

The switch ranges given below refer to the limits within which the switch point may be infinitely adjusted. The actual flow throughput can, depending on the flow velocity, be much greater.

## Special advantages

- wide switching ranges
- small switch hysteresis
- infinitely adjustable switchpoint
- high reliability

## Switch hysteresis

Hysteresis is the difference in flow between the switch closing and opening again. The difference is the result of the movement required by the float to reclose the open contact. The shorter the distance, the smaller the hysteresis and therefore the more accurate the instrument. By means of the careful choice of magnets and reed switches with especially close tolerances, hysteresis is kept to an absolute minimum.

Low hysteresis is of great advantage where particular accuracy is demanded, especially in flow systems where only small increases in flow throughput above the necessary minimum can be achieved.

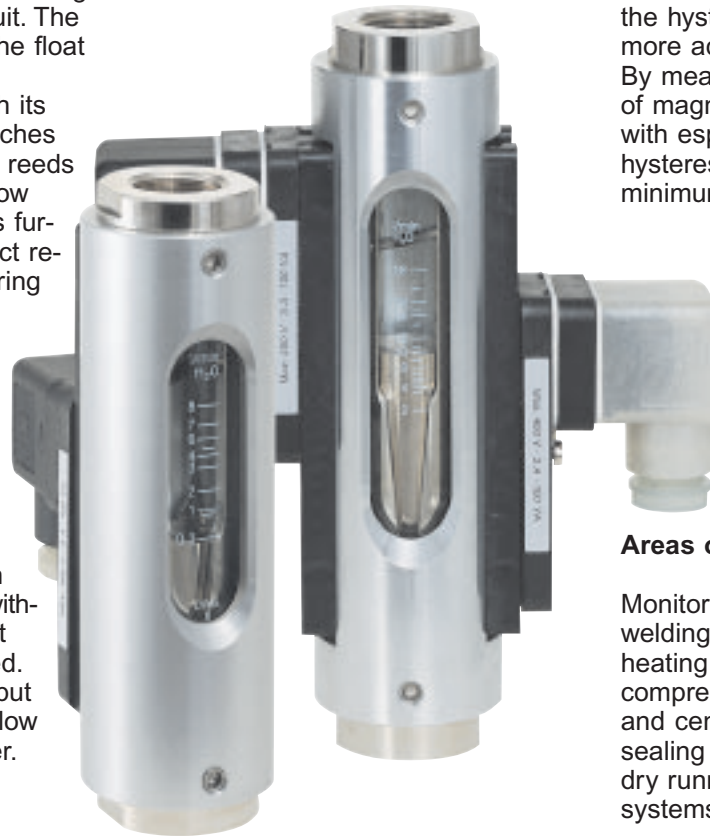

**DWG flow monitors are flow and not pressure dependent.**

## Areas of application

Monitoring of cooling circuits in welding machines, induction heating plants, transformers, compressors, heat exchangers and centrifuges. Monitoring of sealing media for seals and pump dry running, motor cooling systems etc.

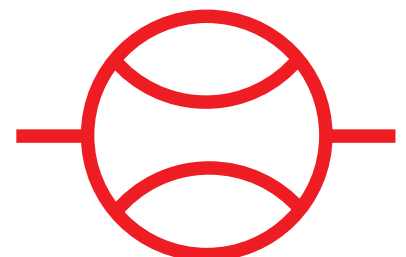

**Installation:**

- The installation of the flow switch in the system has to be vertical.
- Flow direction from bottom to top.
- Flow straitening sections of 10x DN upstream and 5x DN downstream are strongly recommended.
- The medium should not contain any solid particles. We recommend the installation of strainers, model SF, SFD or SFM.
- Do not install the equipment within inductive fields.
- Do not exceed the max.electrical ratings of the switch contact under no circumstances.

For installation and set-up assistance please "refer" to instruction manual.

**Connection Diagram:**

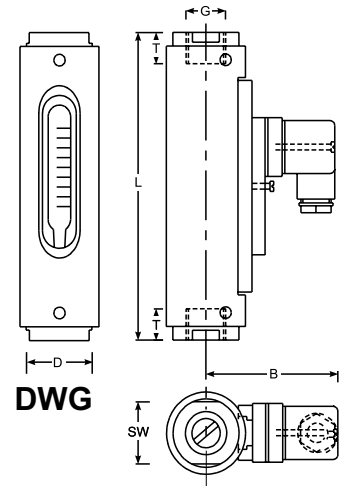
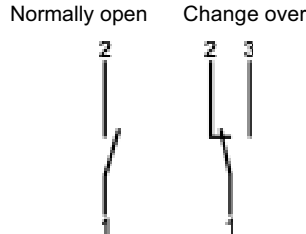

**Summary of Types DWG**

Type	Switch range* l/min H <sub>2</sub> O	Overall dimensions mm							Weight approx. g
		SW	D	B	G	DN	T	L	
DWG - 1,5	0,1 - 1,5	32	43	73	1/4"	8	14	132	625
DWG - 3	0,2 - 3,0				3/8"				
DWG - 8	0,3 - 8,0				1/2"				
DWG - 12	1 - 12	32	43	73	1/2"	15	15	135	650
DWG - 18	2 - 18				3/4"				
DWG - 35	3 - 35				3/4"				
DWG - 50	4 - 50	41	50	76	1"	25	19	184	1000

\* Other switch ranges on request

**Operating Data: DWG**

Maximum pressure:	PN 10 bar
Pressure drop:	0,01 - 0,2 bar
Maximum temperature:	120 °C (optional 160°C)
Accuracy:	± 5% of final value

Electrical data:	Normally open SPST N.O.	Change over SPDT
IP 65 (plug connection DIN 43650)	max. 250V • 3A • 100VA	max. 250V • 1,5A • 50VA
IP 67 (with sealed in 1m cable)		
EEx m II T6 (with sealed in 2m cable)	max. 250V • 2A • 60VA	max. 250V • 1A • 30VA
EEx ia IIC T6 (with sealed in 2m cable)	max. 45V • 1A	max. 45V • 1A
Output signal:	The contact switches off, if minimum flow is below setpoint	
Power supply:	Not necessary (reed contacts)	

Other plug types or cable lengths on request

Materials:	brass	stainless steel
Wetted parts:	brass nickel-plated	st.st. 1.4571
Glass: (wetted parts)	Duran 50	
Seals: (wetted parts)	Perbunan (optional Viton, EPDM) *	Viton (optional Perbunan, EPDM) *
Housing: (non wetted part)	aluminium	

\* Other seal materials on request

Valid are the general terms and conditions of Meister Strömungstechnik GmbH • Errors and technical changes excepted

### Installation:

- The installation of the flow switch in the system has to be vertical.
- Flow direction from bottom to top.
- Flow straightening sections of 10x DN upstream and 5x DN downstream are strongly recommended.
- The medium should not contain any solid particles. We recommend the installation of strainers, model SF, SFD or SFM.
- Do not install the equipment within inductive fields.
- Do not exceed the max. electrical ratings of the switch contact under no circumstances.  
For installation and set-up assistance please "refer" to instruction manual.

### Connection Diagram:

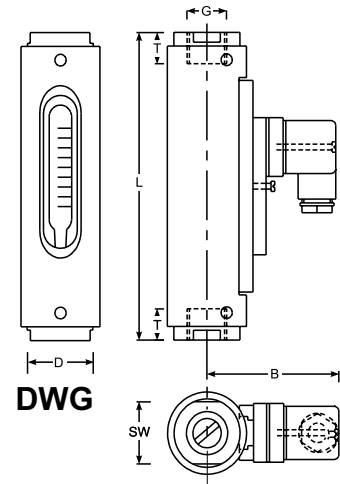
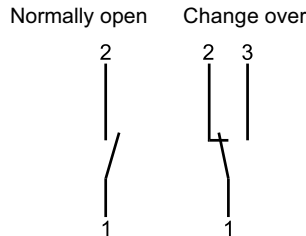

### Summary of Types DWG - Air

Type	Switch range* NI/min Air	Overall dimensions mm							Weight approx. g
		SW	D	B	G	DN	T	L	
DWG - 1,5	3 - 30	32	43	73	1/4"	8	14	132	625
DWG - 3	6 - 60				3/8"	10	14	135	
DWG - 8	6 - 160				1/2"	15	15	135	
DWG - 12	20 - 240				1/2"	15	15	135	
DWG - 18	40 - 360	32	43	73	3/4"	20	16	167	650
DWG - 35	60 - 700	41	50	76	3/4"	20	18	164	850
DWG - 50	60 - 825				1"	25	19	184	1000
DWG - 100	200 - 1350	41	50	76	1"	25	19	200	1100
DWG - 150	350 - 2750	46	55	79	1 1/4"	32	21	222	1300

\* Other switch ranges on request / NI/min at 1 bar abs. 20°C

### Operating Data: DWG-Air

Maximum pressure:	PN 10 bar	
Pressure drop:	0,01 - 0,2 bar	
Maximum temperature:	120 °C (optional 160°C)	
Accuracy:	± 5% of final value	
<b>Electrical data:</b>	<b>Normally open SPST N.O.</b>	<b>Change over SPDT</b>
IP 65 (plug connection DIN 43650)	max. 250V • 3A • 100VA	max. 250V • 1,5A • 50VA
IP 67 (with sealed in 1m cable)		
EEx m II T6 (with sealed in 2m cable)	max. 250V • 2A • 60VA	max. 250V • 1A • 30VA
EEx ia IIC T6 (with sealed in 2m cable)	max. 45V • 1A	max. 45V • 1A
Output signal:	The contact switches off, if minimum flow is below setpoint	
Power supply:	Not necessary (reed contacts)	
Other plug types or cable lengths on request		
<b>Materials:</b>	<b>brass</b>	<b>stainless steel</b>
Wetted parts:	brass nickel-plated	st.st. 1.4571
Glass: (wetted parts)	Duran 50	
Seals: (wetted parts)	Perbunan (optional Viton, EPDM) *	Viton (optional Perbunan, EPDM) *
Housing: (non wetted part)	aluminium	

\* Other seal materials on request

Valid are the general terms and conditions of Meister Strömungstechnik GmbH • Errors and technical changes excepted