

# Flow Measurement

## SITRANS F M

### Transmitter MAG 5000/6000

#### Overview



Transmitter MAG 5000/6000 compact version (left) and 19" insert version (right)

The MAG 5000 and 6000 are transmitters engineered for high performance, easy installation, commissioning and maintenance. The transmitters evaluate the signals from the SITRANS F M sensors type MAG 1100, MAG 1100 F, MAG 3100, MAG 3100 P and MAG 5100 W.

Transmitter types:

- MAG 5000: Max. measuring error  $\pm 0.4\% \pm 1 \text{ mm/s}$  (incl. sensor)
- MAG 6000: Max. measuring error  $\pm 0.2\% \pm 1 \text{ mm/s}$  (incl. sensor, see also sensor specifications) and with additional features such as: "plug & play" add-on bus modules; integrated batch functions.

#### Benefits

- Superior signal resolution for optimum turn down ratio
- Digital signal processing with many possibilities
- Automatic reading of SENSORPROM data for easy commissioning
- User configurable operation menu with password protection.
- 3 lines, 20 characters display in 11 languages.
- Flow rate in various units
- Totalizer for forward, reverse and net flow as well as additional information available
- Multiple functional outputs for process control, minimum configuration with analogue, pulse/frequency and relay output (status, flow direction, limits)
- Comprehensive self-diagnostic for error indication and error logging (see under SITRANS F M diagnostics)
- Batch control (MAG 6000 only)
- Custody transfer approval: PTB, OIML R 75, OIML R 117, OIML R 49, MI-001 and PTB K 7.2 for chilled water
- MAG 6000 with add-on bus modules for HART, FOUNDATION Fieldbus H1, DeviceNet, Modbus RTU/RS 485, PROFIBUS PA and DP

#### Application

The SITRANS F M flowmeters are suitable for measuring the flow of almost all electrically conductive liquids, pastes and slurries. The main applications can be found in:

- Water and waste water
- Chemical and pharmaceutical industries
- Food and beverage industries
- Power generation and utility

#### Design

The transmitter is designed as either IP67 NEMA 4X/6 enclosure for compact or wall mounting or 19" version as a 19" insert as a base to be used in:

- 19" rack systems
- Panel mounting IP20/NEMA 1 (prepared for IP65/NEMA 2 display side)
- Back of panel mounting IP20/NEMA 1
- Wall mounting IP66/NEMA 4X

Several options on 19" versions are available such as:

- Transmitters mounted in safe area for Ex ATEX approved flow sensors (incl. barriers)
- Transmitters with electrode cleaning unit on request

#### Function

The MAG 5000/6000 are transmitters with a build-in alphanumeric display in several languages. The transmitters evaluate the signals from the associated electromagnetic sensors and also fulfil the task of a power supply unit which provides the magnet coils with a constant current.

Further information on connection, mode of operation and installation can be found in the data sheets for the sensors.

#### Displays and controls

Operation of the transmitter can be carried out using:

- Control and display unit
- HART communicator
- PC/laptop and SIMATIC PDM software via HART communication
- PC/laptop and SIMATIC PDM software using PROFIBUS or Modbus communication

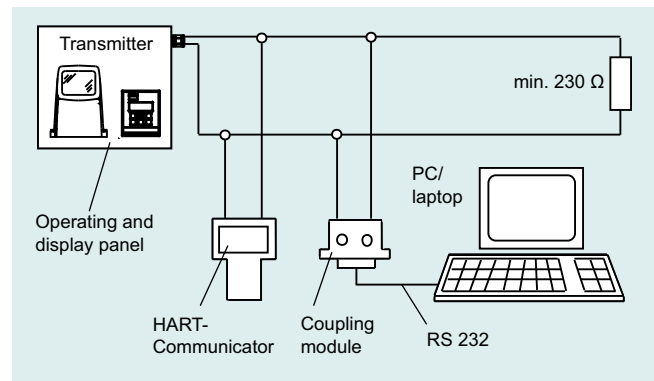

HART communication

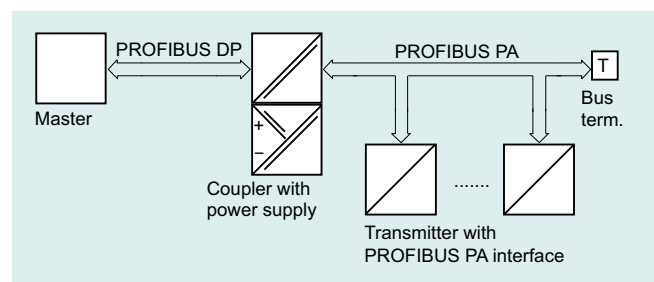

PROFIBUS PA communication

**Technical specifications**

<b>Mode of operation and design</b>	
Measuring principle	Electromagnetic with pulsed constant field
Empty pipe	Detection of empty pipe (special cable required in remote mounted installation)
Excitation frequency	Depend on sensor size
Electrode input impedance	$> 1 \times 10^{14} \Omega$
<b>Input</b>	
<b>Digital input</b>	11 ... 30 V DC, $R_i = 4.4 \text{ K}\Omega$
• Activation time	50 ms
• Current	$I_{11 \text{ V DC}} = 2.5 \text{ mA}$ , $I_{30 \text{ V DC}} = 7 \text{ mA}$
<b>Output</b>	
<b>Current output</b>	
• Signal range	0 ... 20 mA or 4 ... 20 mA
• Load	$< 800 \Omega$
• Time constant	0.1 ... 30 s, adjustable
<b>Digital output</b>	
• Frequency	0 ... 10 kHz, 50 % duty cycle (uni/bidirectional)
• Pulse (active)	24 V DC, 30 mA, $1 \text{ K}\Omega \leq R_i \leq 10 \text{ K}\Omega$ , short-circuit-protected (power supplied from flowmeter)
• Pulse (passive)	3 ... 30 V DC, max. 110 mA, $200 \Omega \leq R_i \leq 10 \text{ K}\Omega$ (powered from connected equipment)
• Time constant	0.1 ... 30 s, adjustable
<b>Relay output</b>	
• Time constant	Changeover relay, same as current output
• Load	42 V AC/2 A, 24 V DC/1 A
<b>Low flow cut off</b>	0 ... 9.9 % of maximum flow
<b>Galvanic isolation</b>	All inputs and outputs are galvanically isolated.
<b>Max. measuring error (incl. sensor and zero point)</b>	
• MAG 5000	0.4 % $\pm 1$ mm/s
• MAG 6000	0.2 % $\pm 1$ mm/s
<b>Rated operation conditions</b>	
Ambient temperature	
• Operation	<ul style="list-style-type: none"> <li>• Display version: -20 ... +60 °C (-4 ... +140 °F)</li> <li>• Blind version: -20 ... +60 °C (-4 ... +140 °F)</li> <li>• MI-001 version: -25 ... +55 °C (-13 ... +131 °F)</li> <li>• Custody Transfer (CT) version: -20 ... +50 °C (-4 ... +122 °F)</li> </ul>
• Storage	-40 ... +70 °C (-40 ... +158 °F)
<b>Mechanical load (vibration)</b>	
Compact version	18 ... 1000 Hz, 3.17 g rms, sinusoidal in all directions to IEC 68-2-36
19" insert	1 ... 800 Hz, 1 g, sinusoidal in all directions to IEC 68-2-36
<b>Degree of protection</b>	
Compact version	IP67/NEMA 4X/6 to IEC 529 and DIN 40050 (1 mH <sub>2</sub> O 30 min.)
19" insert	IP20/NEMA 1 to IEC 529 and DIN 40050
<b>EMC performance</b>	
	IEC/EN 61326-1 (all environments) IEC/EN 61326-2-5

<b>Display and keypad</b>	
Totalizer	Two eight-digit counters for forward, net or reverse flow
<b>Display</b>	Background illumination with alphanumeric text, 3 x 20 characters to indicate flow rate, totalized values, settings and faults; Reverse flow indicated by negative sign
Time constant	Time constant as current output time constant
<b>Design</b>	
Enclosure material	Fiber glass reinforced polyamide; stainless steel AISI 316/1.4436 (IP65)
• Compact version	
• 19" insert	Standard 19" insert of aluminum/steel (DIN 41494), width: 21 TE, height: 3 HE
• Back of panel	IP20/NEMA 1; Aluminum
• Panel mounting	IP20/NEMA 1 (prepared for IP65/NEMA 2 display side); ABS plastic
• Wall mounting	IP66/NEMA 4X; ABS plastic
<b>Dimensions</b>	
Compact version	See dimensional drawings
19" insert	See dimensional drawings
<b>Weight</b>	
Compact version	0.75 kg (2 lb)
19" insert	See dimensional drawings
<b>Power supply</b>	
	<ul style="list-style-type: none"> <li>• 115 ... 230 V AC +10 % -15 %, 50 ... 60 Hz</li> <li>• 11 ... 30 V DC or 11 ... 24 V AC</li> </ul>
<b>Power consumption</b>	
	<ul style="list-style-type: none"> <li>• 230 V AC: 17 VA</li> <li>• 24 V AC: 9 VA, <math>I_N = 380 \text{ mA}</math>, <math>I_{ST} = 8 \text{ A}</math> (30 ms)</li> <li>• 12 V DC: 11 W, <math>I_N = 920 \text{ mA}</math>, <math>I_{ST} = 4 \text{ A}</math> (250 ms)</li> </ul> <p><math>I_{ST} = 4 \text{ A}</math> (250 ms): For solar panel please secure stable current supply</p>
<b>Certificates and approvals</b>	
	CE, C-UL general purpose, C-tick; FM Class I, Div 2, CSA Class I, Div 2
Custody transfer approval (MAG 5000/6000 CT)	<ul style="list-style-type: none"> <li>• Cold water: MI-001, PTB/OIML R 49 (pattern approval DE/DK)</li> <li>• Hot water: PTB and DANAK OIML R 75 (pattern approval DE/DK) (MAG 6000 CT)</li> <li>• Chilled water: PTB K 7.2</li> <li>• Other media than water (milk, beer etc.): PTB and DANAK OIML R 117 (pattern approval DE/DK) (MAG 6000 CT)</li> </ul>
<b>Communication</b>	
Standard	
• MAG 5000	Without serial communication or HART as option
• MAG 6000	Prepared for client-mounted add-on modules
Optional (MAG 6000 only)	HART, Modbus RTU/RS 485, FOUNDATION Fieldbus H1, DeviceNet, PROFIBUS PA, PROFIBUS DP as add-on modules
• MAG 5000/6000 CT	No communication modules approved

# Flow Measurement

## SITRANS F M

### Transmitter MAG 5000/6000

#### Safety barrier (e/ia)



Application	For use with MAG 5000/6000 19" and MAG 1100 Ex ATEX/MAG 3100 Ex ATEX		
<b>Ex approval</b>	MAG 1100 Ex [EEx e ia] IIB ATEX MAG 3100 Ex [EEx e ia] IIC ATEX		
<b>Cable parameter</b>	Group	Capacity in $\mu\text{F}$	Inductance in mH
Electrode	IIC	$\leq 4.1$	$\leq 80$
	IIB	$\leq 45$	$\leq 87$
	IIA	$\leq 45$	$\leq 87$
<b>Ambient temperature</b>			
• During operation	-20 ... +50 °C (-4 ... +122 °F)		
• During storage	-20 ... +70 °C (-4 ... +158 °F)		
<b>Enclosure</b>			
• Material	Standard 19" insert in aluminum/steel (DIN 41494)		
• Width	21 TE (4.75")		
• Height	3 HE (5.25")		
• Rating	IP20 / NEMA 1 to EN 60529		
• Mechanical load	1 g, 1 ... 800 Hz sinusoidal in all directions to EN 60068-2-36		

#### Electrode cleaning unit for MAG 5000 or 6000 in 19" insert version







The purpose of electrode cleaning is to remove unwanted deposits on the electrodes in water applications by applying either a DC or AC voltage to the electrodes. AC cleaning is used in waste water applications to remove fatty deposits on the electrodes by warming up the electrode. DC cleaning is used in district heating applications to eliminate electrically conductive deposits.

#### Application for use with transmitters MAG 5000 and 6000 19" to clean the electrodes on sensors MAG 1100 or MAG 3100

- Not to be used with intrinsically safe Ex sensors
  - Not to be used with sensors with Hastelloy and Tantalum electrodes
- Available on request







## Selection and Ordering data

**Transmitter MAG 5000**

Description	Order No.	
Transmitter MAG 5000 Blind for compact and wall mounting; IP67/NEMA 4X/6, fibre glass reinforced polyamide <ul style="list-style-type: none"> <li>• 11 ... 30 V DC/ 11 ... 24 V AC</li> <li>• 115 ... 230 V AC, 50/60 Hz</li> </ul>	◆ <b>7ME6910-1AA30-0AA0</b> ◆ <b>7ME6910-1AA10-0AA0</b>	
Transmitter MAG 5000 Display for compact and wall mounting; IP67/NEMA 4X/6, fibre glass reinforced polyamide <ul style="list-style-type: none"> <li>• 11 ... 30 V DC/ 11 ... 24 V AC</li> <li>• 115 ... 230 V AC, 50/60 Hz</li> <li>• 115 ... 230 V AC, 50/60 Hz, with HART</li> </ul>	◆ <b>7ME6910-1AA30-1AA0</b> ◆ <b>7ME6910-1AA10-1AA0</b> <b>7ME6910-1AA10-1BA0</b>	
Transmitter MAG 5000 CT for compact and wall mounting, approved for custody transfer (only with approval marks, no verification – only a complete flowmeter can be verified, i.e. sensor together with the transmitter); IP67/NEMA 4X/6, fibre glass reinforced polyamide <ul style="list-style-type: none"> <li>• 11 ... 30 V DC/ 11 ... 24 V AC</li> <li>• 115 ... 230 V AC, 50/60 Hz</li> </ul>	◆ <b>7ME6910-1AA30-1AB0</b> ◆ <b>7ME6910-1AA10-1AB0</b>	
Transmitter MAG 5000 for 19" rack and wall mounting <ul style="list-style-type: none"> <li>• 11 ... 30 V DC/ 11 ... 24 V AC</li> <li>• 115 ... 230 V AC, 50/60 Hz</li> </ul>	<b>7ME6910-2CA30-1AA0</b> <b>7ME6910-2CA10-1AA0</b>	

◆ Short lead time (details in PMD)





**Transmitter MAG 6000**

Description	Order No.	
Transmitter MAG 6000 Blind for compact and wall mounting; IP67/NEMA 4X/6, fibre glass reinforced polyamide <ul style="list-style-type: none"> <li>• 11 ... 30 V DC/ 11 ... 24 V AC</li> <li>• 115 ... 230 V AC, 50/60 Hz</li> </ul>	◆ <b>7ME6920-1AA30-0AA0</b> ◆ <b>7ME6920-1AA10-0AA0</b>	
Transmitter MAG 6000 for compact and wall mounting; IP67/NEMA 4X/6, fibre glass reinforced polyamide <ul style="list-style-type: none"> <li>• 11 ... 30 V DC/ 11 ... 24 V AC</li> <li>• 115 ... 230 V AC, 50/60 Hz</li> </ul>	◆ <b>7ME6920-1AA30-1AA0</b> ◆ <b>7ME6920-1AA10-1AA0</b>	
Transmitter MAG 6000 for compact and wall mounting; IP65/NEMA 4, stainless steel AISI 316/1.4436 (only for sensor with SS terminal box) (for remote installation order SS terminal box separately) <ul style="list-style-type: none"> <li>• 11 ... 30 V DC/ 11 ... 24 V AC</li> <li>• 115 ... 230 V AC, 50/60 Hz</li> </ul>	<b>7ME6920-1QA30-1AA0</b> <b>7ME6920-1QA10-1AA0</b>	
Transmitter MAG 6000 CT for compact and wall mounting, approved for custody transfer (no communication modules possible; only with approval marks, no verification – only a complete flowmeter can be verified, i.e. sensor together with the transmitter); IP67/NEMA 4X/6, fibre glass reinforced polyamide <ul style="list-style-type: none"> <li>• 11 ... 30 V DC/ 11 ... 24 V AC</li> <li>• 115 ... 230 V AC, 50/60 Hz</li> </ul>	◆ <b>7ME6920-1AA30-1AB0</b> ◆ <b>7ME6920-1AA10-1AB0</b>	
Transmitter MAG 6000 SV for compact and wall mounting; special excitation 44 Hz settings for Batch application DN ≤ 25/1" IP67/NEMA 4X/6, fibre glass reinforced polyamide <ul style="list-style-type: none"> <li>11 ... 30 V DC/ 11 ... 24 V AC</li> <li>115 ... 230 V AC, 50/60 Hz</li> </ul>	<b>7ME6920-1AB30-1AA0</b> <b>7ME6920-1AB10-1AA0</b>	
Transmitter MAG 6000 for 19" rack and wall mounting <ul style="list-style-type: none"> <li>• 11 ... 30 V DC/ 11 ... 24 V AC</li> <li>• 115 ... 230 V AC, 50/60 Hz</li> </ul>	◆ <b>7ME6920-2CA30-1AA0</b> ◆ <b>7ME6920-2CA10-1AA0</b>	

# Flow Measurement

## SITRANS F M

### Transmitter MAG 5000/6000

Description	Order No.	
Transmitter MAG 6000 SV for 19" rack and wall mounting; special excitation 44 Hz settings for Batch application DN ≤ 25/1" <ul style="list-style-type: none"> <li>• 11 ... 30 V DC / 11 ... 24 V AC</li> <li>• 115 ... 230 V AC, 50/60 Hz</li> </ul>	<b>7ME6920-2CB30-1AA0</b> <b>7ME6920-2CB10-1AA0</b>	
MAG 6000 with IP66/NEMA 4X enclosure; 115 ... 230 V AC, 50/60 Hz; cable gland PG13.5	<b>7ME6920-2EA10-1AA0</b>	
MAG 6000 with safety barrier for Ex-approved sensors, complete mounted with IP66/NEMA 4X wall mounting enclosure, ATEX, 115 ... 230 V AC, 50/60 Hz; cable gland PG13.5	<b>7ME6920-2MA11-1AA0</b>	
MAG 6000 SV, 19" insert, in IP66/NEMA 4X, ABS plastic enclosure, excitation frequency 44 Hz for Batch application DN ≤ 25/1"; cable gland PG13.5	<b>7ME6920-2EB30-1AA0</b> <b>7ME6920-2EB10-1AA0</b>	

◆ Short lead time (details in PMD)

### Operating instructions for SITRANS F M MAG 5000/6000

Description	Order No.	
For SITRANS F M MAG 5000/6000 IP67	<b>A5E02338368</b> <b>A5E02944982</b> <b>A5E02944995</b> <b>A5E02944990</b>	
For SITRANS F M MAG 5000/6000 19"	<b>A5E02082880</b>	

This device is shipped with a Quick Start guide and a CD containing further SITRANS F literature.

**All literature is also available for free at:**  
<http://www.siemens.com/flowdocumentation>

### Communication modules for MAG 6000



Description	Order No.	
HART (not for MAG 6000 I)	◆ <b>FDK:085U0226</b>	
Modbus RTU/RS 485	◆ <b>FDK:085U0234</b>	
PROFIBUS PA Profile 3	◆ <b>FDK:085U0236</b>	
PROFIBUS DP Profile 3	◆ <b>FDK:085U0237</b>	
DeviceNet	◆ <b>FDK:085U0229</b>	
FOUNDATION Fieldbus H1	◆ <b>A5E02054250</b>	

### Operating instructions for SITRANS F add-on modules







Description	Order No.	
HART		
• English	<b>A5E03089708</b>	
PROFIBUS PA/DP		
• English	<b>A5E00726137</b>	
• German	<b>A5E01026429</b>	
MODBUS		
• English	<b>A5E00753974</b>	
• German	<b>A5E03089262</b>	
• Spanish	<b>A5E03089278</b>	
• French	<b>A5E03089265</b>	
FOUNDATION Fieldbus		
• English	<b>A5E02318728</b>	
• German	<b>A5E02488856</b>	
• Spanish	<b>A5E02512177</b>	
• French	<b>A5E02512169</b>	
DeviceNet		
• English	<b>A5E03089720</b>	





This device is shipped with a Quick Start guide and a CD containing further SITRANS F literature.

### Accessories for MAG 5000 and MAG 6000

Description	Order No.	
Wall mounting unit for IP67/NEMA 4X/6 version, wall bracket, terminal box in polyamide		
• 4 x M20 cable glands	◆ <b>FDK:085U1018</b>	
• 4 x 1/2" NPT cable glands	◆ <b>FDK:085U1053</b>	
Sun lid for MAG 5000/6000 transmitter (Frame and lid)	<b>A5E02328485</b>	
Cable for standard electrode or coil, 3 x 1.5 mm <sup>2</sup> / 18 gage with shield PVC; Temperature range: -30 ... +70 °C (-22 ... +158 °F)		
• 10 m (33 ft)	◆ <b>FDK:083F0121</b>	
• 20 m (65 ft)	◆ <b>FDK:083F0210</b>	
• 40 m (130 ft)	◆ <b>FDK:083F0211</b>	
• 60 m (200 ft)	◆ <b>FDK:083F0212</b>	
• 100 m (330 ft)	◆ <b>FDK:083F0213</b>	
• 150 m (500 ft)	<b>FDK:083F3052</b>	
• 200 m (650 ft)	<b>FDK:083F3053</b>	
• 500 m (1650 ft)	<b>FDK:083F3054</b>	

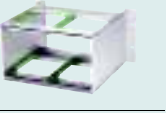
### Transmitter MAG 5000/6000

Description	Order No.	
<p>Electrode cable for empty pipe or low conductivity<sup>1)</sup>, double shielded, 3 x 0.25 mm<sup>2</sup>. Temperature range : -30 ... +70 °C (-22 ... +158 °F)</p> <ul style="list-style-type: none"> <li>• 10 m (33 ft) ◆ <b>FDK:083F3020</b></li> <li>• 20 m (65 ft) ◆ <b>FDK:083F3095</b></li> <li>• 40 m (130 ft) <b>FDK:083F3094</b></li> <li>• 60 m (200 ft) <b>FDK:083F3093</b></li> <li>• 100 m (330 ft) <b>FDK:083F3092</b></li> <li>• 150 m (500 ft) <b>FDK:083F3056</b></li> <li>• 200 m (650 ft) <b>FDK:083F3057</b></li> <li>• 500 m (1650 ft) <b>FDK:083F3058</b></li> </ul>		
<p>Low-noise electrode coax cable for low conductivity and high vibration levels of cables, 3 x 0.13 mm<sup>2</sup></p> <ul style="list-style-type: none"> <li>• 2 m (6.6 ft) <b>A5E02272692</b></li> <li>• 5 m (16.5 ft) <b>A5E02272723</b></li> <li>• 10 m (33 ft) <b>A5E02272730</b></li> </ul>		
<p>Cable kit with standard coil cable<sup>1)</sup>, 3 x 1.5 mm<sup>2</sup>/18 gage with shield PVC and electrode cable double shielded, 3 x 0.25 mm<sup>2</sup>. Temperature range: -30 ... +70 °C (-22 ... +158 °F)</p> <ul style="list-style-type: none"> <li>• 5 m (16.5 ft) ◆ <b>A5E02296329</b></li> <li>• 10 m (33 ft) ◆ <b>A5E01181647</b></li> <li>• 15 m (49 ft) ◆ <b>A5E02296464</b></li> <li>• 20 m (65 ft) ◆ <b>A5E01181656</b></li> <li>• 25 m (82 ft) ◆ <b>A5E02296490</b></li> <li>• 30 m (98 ft) ◆ <b>A5E02296494</b></li> <li>• 40 m (130 ft) ◆ <b>A5E01181686</b></li> <li>• 50 m (164 ft) ◆ <b>A5E02296498</b></li> <li>• 60 m (200 ft) <b>A5E01181689</b></li> <li>• 100 m (330 ft) <b>A5E01181691</b></li> <li>• 150 m (500 ft) <b>A5E01181699</b></li> <li>• 200 m (650 ft) <b>A5E01181703</b></li> <li>• 500 m (1650 ft) <b>A5E01181705</b></li> </ul>		
<p>Potting kit for terminal box of flow sensors for IP68/NEMA 6P (not for Ex sensors)</p>	◆ <b>FDK:085U0220</b>	
<p>19" safety barrier (21 TE) [EEx e ia] IIC for MAG 1100 Ex sensors and MAG 3100 Ex sensors, incl. back plate</p>	<b>FDK:083F5034</b>	
<p>Panel mounting enclosure for 19" insert (21 TE); IP65/NEMA 2 enclosure in ABS plastic for front panel mounting</p>	<b>FDK:083F5030</b>	
<p>Panel mounting enclosure for 19" insert (42 TE); IP65/NEMA 2 enclosure in ABS plastic for front panel mounting</p>	<b>FDK:083F5031</b>	

Description	Order No.	
<p>Back of panel mounting enclosure for 19" insert (21 TE); IP20/NEMA 1 enclosure in aluminum</p>	<b>FDK:083F5032</b>	
<p>Back of panel mounting enclosure for 19" insert (42 TE); IP20/NEMA 1 enclosure in aluminum</p>	<b>FDK:083F5033</b>	
<p>IP66/NEMA 4X, wall mounting enclosure for 19" inserts (without back plates). Use with PCB A5E02559813 or A5E02559814</p> <ul style="list-style-type: none"> <li>• 21 TE <b>FDK:083F5037</b></li> <li>• 42 TE <b>FDK:083F5038</b></li> </ul>		
<p>Front cover (7TE) for panel mounting enclosure</p>	<b>FDK:083F4525</b>	
<p>Sun shield for remote MAG 5000/6000 transmitters</p>	<b>A5E01209496</b>	
<p>Sun Shield for compact MAG 5000/6000 transmitters on MAG 3100 (DN 15 ... 2000 (1/2" ... 78") or MAG 5100 W (DN 150 ... 1200 (6" ... 48"))</p>	<b>A5E01209500</b>	

◆ Short lead time (details in PMD)







1) Not for MAG 6000 with safety barrier



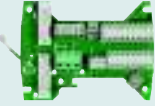

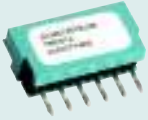





# Flow Measurement

## SITRANS F M

### Transmitter MAG 5000/6000

#### Spare parts

Description	Order No.	
Connection board (for polyamide terminalbox) <ul style="list-style-type: none"> <li>• 12 ... 24 V</li> <li>• 115 ... 230 V</li> </ul>	<b>A5E02559817</b> <b>A5E02559816</b>	
Connection board (for stainless steel terminal- box) <ul style="list-style-type: none"> <li>• 12 ... 24 V</li> <li>• 115 ... 230 V</li> </ul>	<b>A5E02604280</b> <b>A5E02604272</b>	
19" enclosure, 12 ... 24 V, 115 ... 230 V <ul style="list-style-type: none"> <li>• Connection board for stan-                dard 19" transmitter</li> </ul>	<b>A5E02559809</b>	
<ul style="list-style-type: none"> <li>• Connection board for transmitter ia and safety barrier</li> </ul>	<b>A5E02559810</b>	
<ul style="list-style-type: none"> <li>• Connection board for transmitter ia/ib and safety barrier (only for sensors produced before October 2007)</li> </ul>	<b>A5E02559811</b>	
<ul style="list-style-type: none"> <li>• Connection board for transmitter and cleaning unit</li> </ul>	<b>FDK:083F4123</b>	
SENSORPROM memory unit (Sensor code and serial numbers must be specified on order) <ul style="list-style-type: none"> <li>• 2 kB                (for MAG 5000/6000/                MAG 6000 I)</li> <li>• 250 B                (for MAG 2500/3000)</li> </ul>	<b>FDK:085U1005</b> <b>FDK:085U1008</b>	
Display unit for MAG 5000/6000 <ul style="list-style-type: none"> <li>• Black neutral front</li> </ul>	<b>FDK:085U1038</b>	
<ul style="list-style-type: none"> <li>• Siemens front</li> </ul>	<b>FDK:085U1039</b>	
Display unit for 19" versions	<b>FDK:085U3349</b>	

Description	Order No.	
Cable glands, for above cable, 4 pcs. <ul style="list-style-type: none"> <li>• M20</li> <li>• ½" NPT</li> </ul>	<b>A5E00822490</b> <b>A5E00822501</b>	
Sealing screws for sensor/ transmitter, 2 pcs	<b>FDK:085U0221</b>	
Terminal box, in polyamide, inclusive lid <ul style="list-style-type: none"> <li>• M20</li> <li>• ½" NPT</li> </ul>	<b>FDK:085U1050</b> <b>FDK:085U1052</b>	
Terminal box lid, in polyam- ide	<b>FDK:085U1003</b>	
Terminal box, in stainless steel, inclusive lid for MAG 6000 in stainless steel and for all Ex sensors <ul style="list-style-type: none"> <li>• M20</li> <li>• ½" NPT</li> </ul>	<b>A5E00836867</b> <b>A5E00836868</b>	
Terminal box (3A) for MAG 1100 F in polyamide, inclusive lid <ul style="list-style-type: none"> <li>• M20</li> <li>• ½" NPT</li> </ul>	<b>A5E00822478</b> <b>A5E00822479</b>	
Wall unit enclosure IP66, 12 ... 24 V, 115 ... 230 V <ul style="list-style-type: none"> <li>• PCB for standard                transmitter</li> <li>• PCB for transmitter ia/e                and safety barrier</li> <li>• PCB for transmitter ia/ib                and safety barrier                (7ME6130, 7ME6150 and                7ME6330)</li> <li>• PCB for transmitter and                cleaning unit</li> </ul>	<b>A5E02559813</b> <b>A5E02559814</b> <b>A5E02559812</b> <b>A5E02559815</b>	    

### Dimensional drawings

#### Transmitter IP67/NEMA 4X/6 compact polyamide

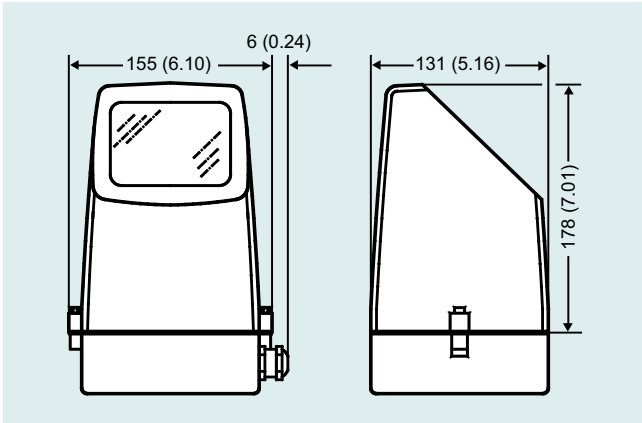

Transmitter compact mounted, dimensions in mm (inch)

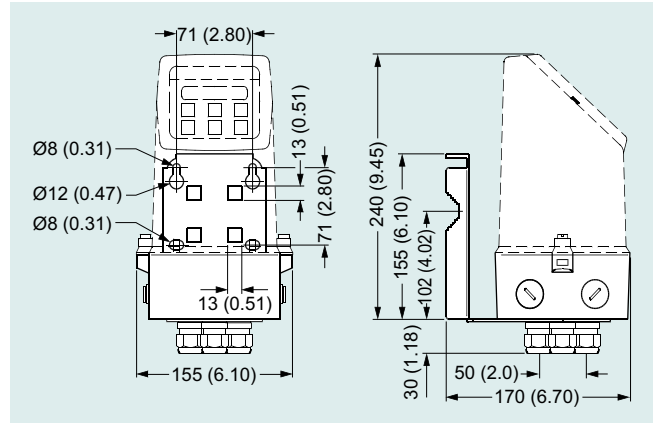

Transmitter wall mounted, dimensions in mm (inch)

#### Transmitter, 19" IP20/NEMA 1 standard unit

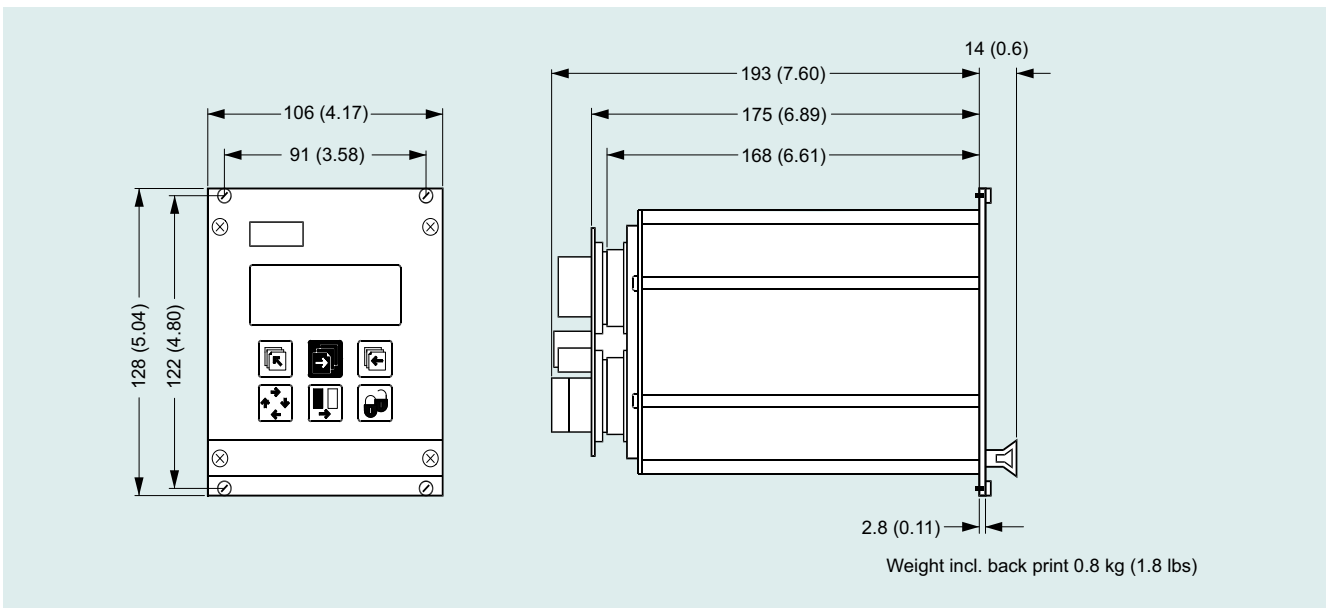

Dimensions in mm (inch)



# Flow Measurement SITRANS F M

## Transmitter MAG 5000/6000

**Transmitter, wall mounting IP66/NEMA 4X, 21 TE**

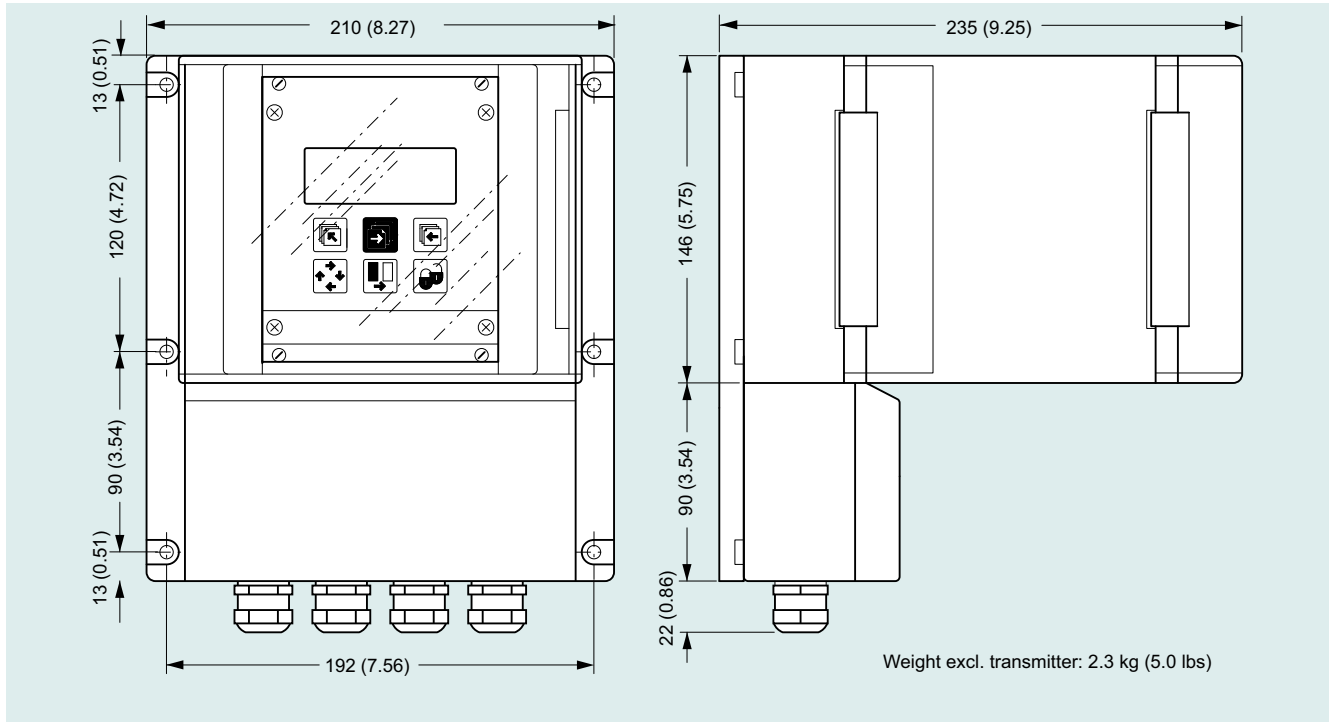

Dimensions in mm (inch)

**Transmitter, wall mounting IP66/NEMA 4X, 42 TE**

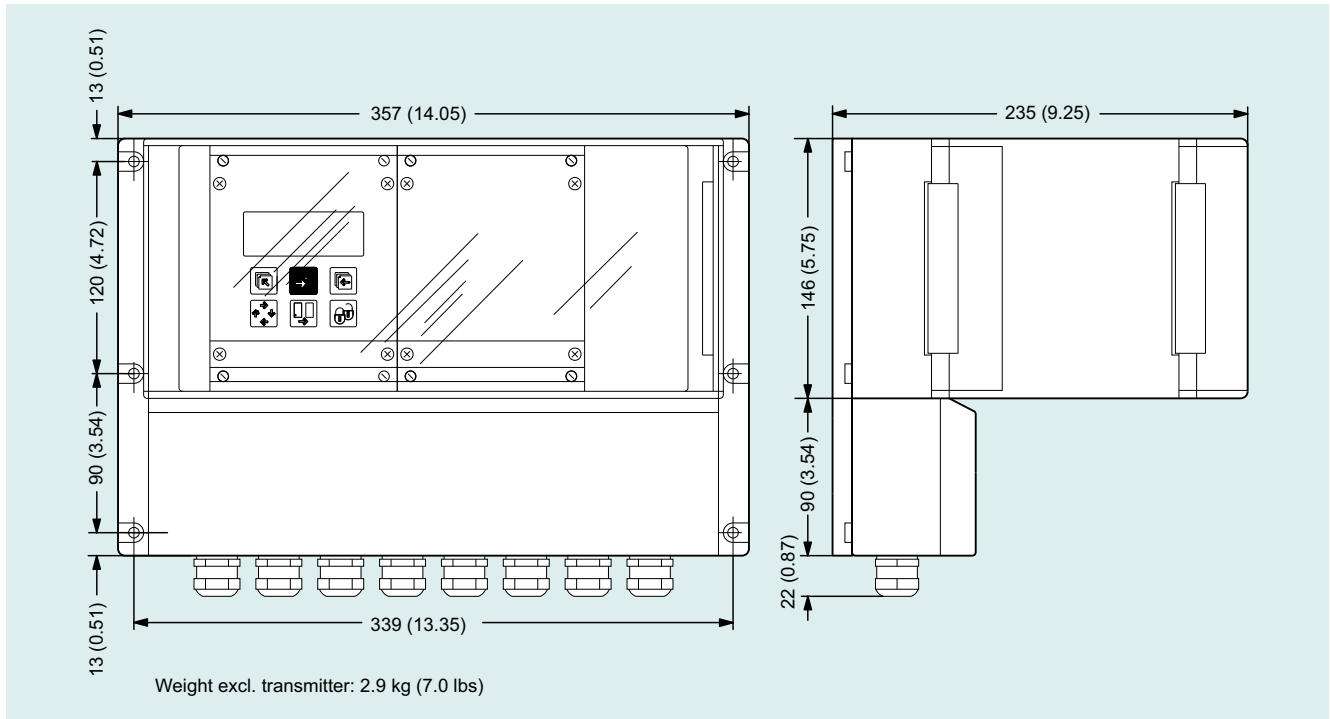

Dimensions in mm (inch)

3

## Transmitter MAG 5000/6000

### Transmitter, panel front IP20/NEMA 1, 21 TE

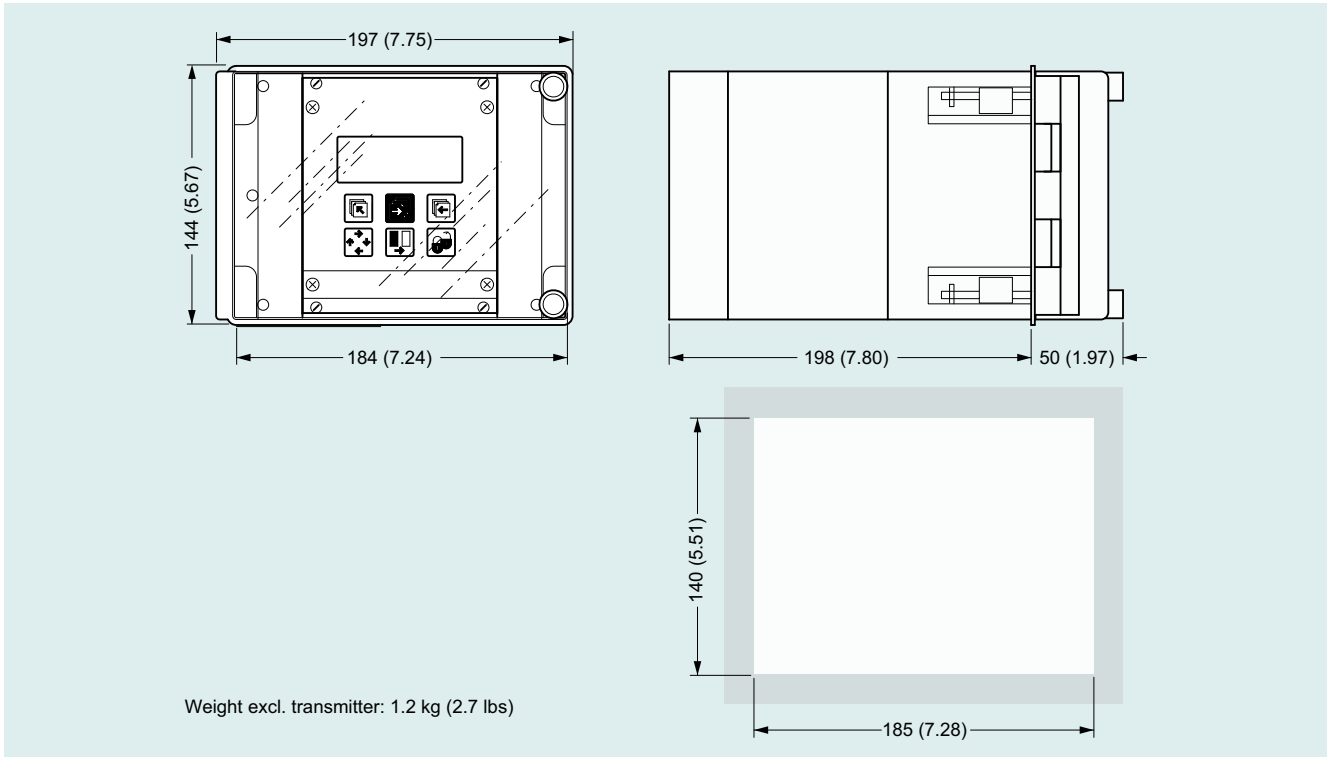

Dimensions in mm (inch)

### Transmitter, panel front IP20/NEMA 1, 42 TE

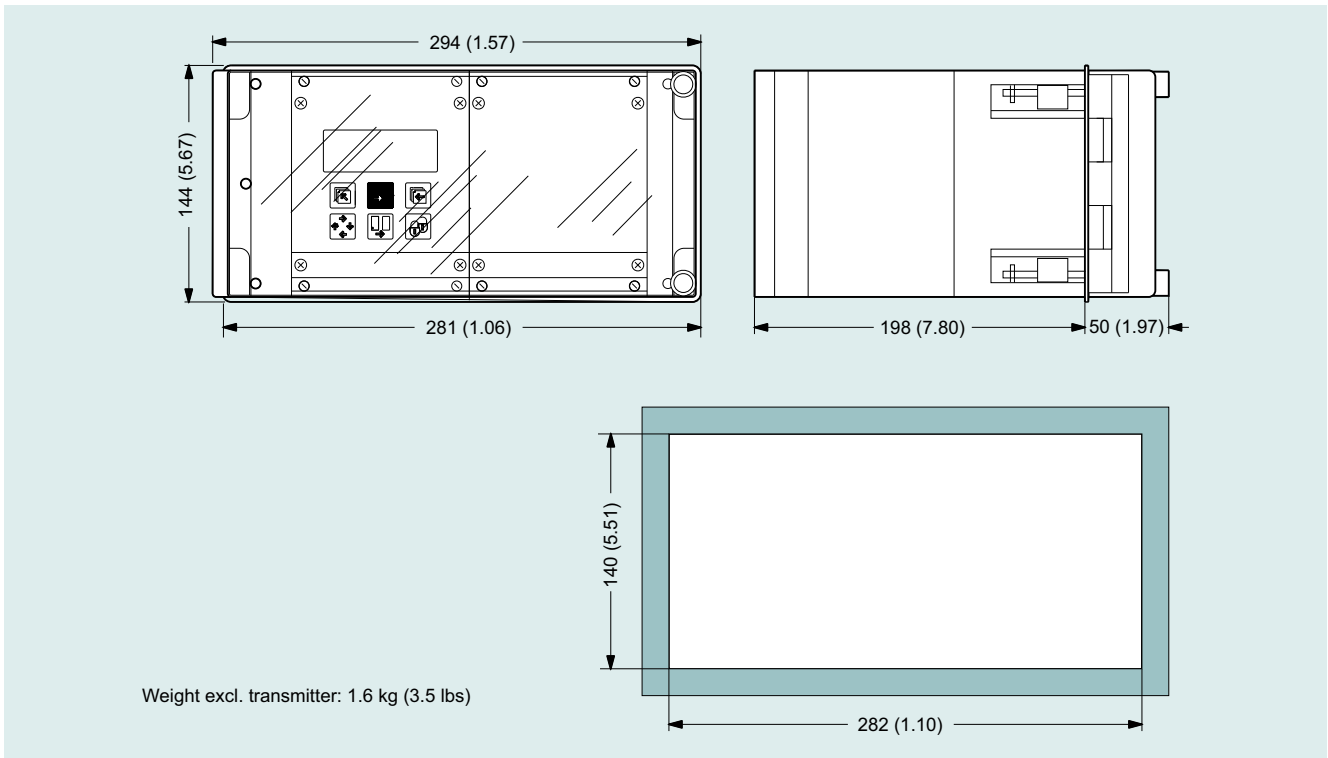

Dimensions in mm (inch)

# Flow Measurement SITRANS F M

## Transmitter MAG 5000/6000

**Transmitter, back of panel IP20/NEMA 1, 21 TE**

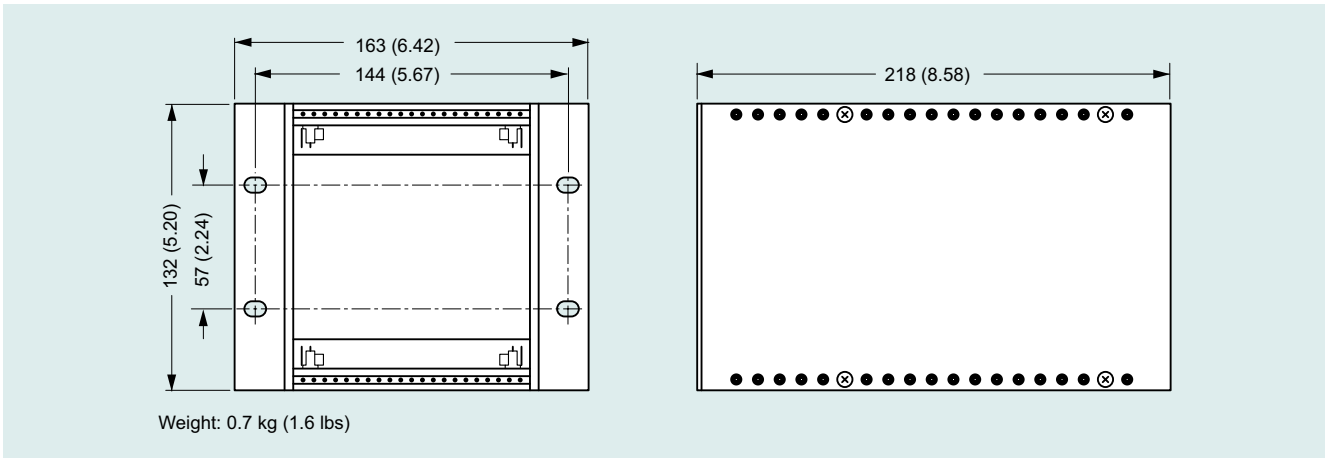

Dimensions in mm (inch)

**Transmitter, back of panel IP20/NEMA 1, 42 TE**

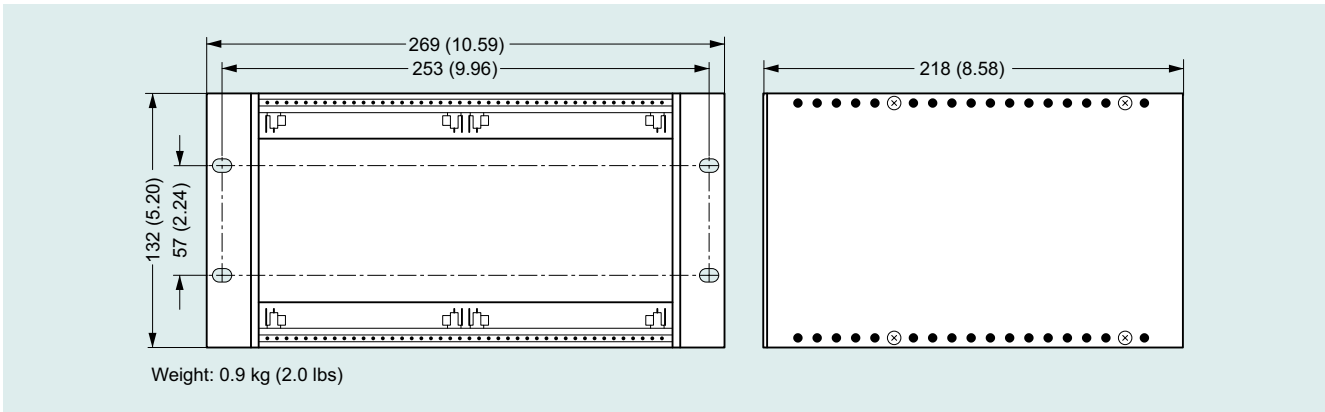

Dimensions in mm (inch)

3

### Schematics

#### Electrical connection

##### Grounding

PE must be connected due to safety class 1 power supply.

##### Mechanical counters

When mounting a mechanical counter to terminals 57 and 58 (active output), a 1000  $\mu$ F capacitor must be connected to the terminals 56 and 58. Capacitor + is connected to terminal 56 and capacitor - to terminal 58.

##### Output cables

If the output cable length is long in noisy environment, we recommend to use shielded cable.

